



CREATE YOUR OWN RUBE GOLDBERG MACHINE (ALL AGES)

Ages 4 to 7 (Level 1)

Description:	Teach your learners the principles of engineering and the values of resilience, creativity, and attention to detail with this hands-on activity.
Leading question:	How can we create a machine that helps us do something useful or fun in our house?
Age group:	4-7 years old
Subjects:	Science (physics, engineering)
Total time required:	~ 30-50 mins per day – 2.5-4 hours total over 5 days
Self-guided / Supervised activity:	Supervised by parents / guardians
Resources required:	Pencil, color pens, paper/notebook, household items to create the machine (ball, toy car, Legos, tape, straws, cards, dominoes, strings, etc. - any items found at home)

Day	Time	Activity and Description
1	10-20 minutes	<p>Discussion:</p> <ul style="list-style-type: none"> • What is motion? <ul style="list-style-type: none"> ○ Let the learner reflect and answer. They may refer to their science textbook ○ Explain that motion is when something moves from one place to another • How do things move? The learner will stand up and act out how these objects move: <div style="text-align: center;">  </div> <ul style="list-style-type: none"> • Do these objects move on their own? <ul style="list-style-type: none"> ○ Let the learner reflect and answer ○ Explain that some objects (like people and animals) move on their own, while others (cars and trolleys) need someone to push or start them. This is called force. • What is a machine? <ul style="list-style-type: none"> ○ Let the learner reflect and answer

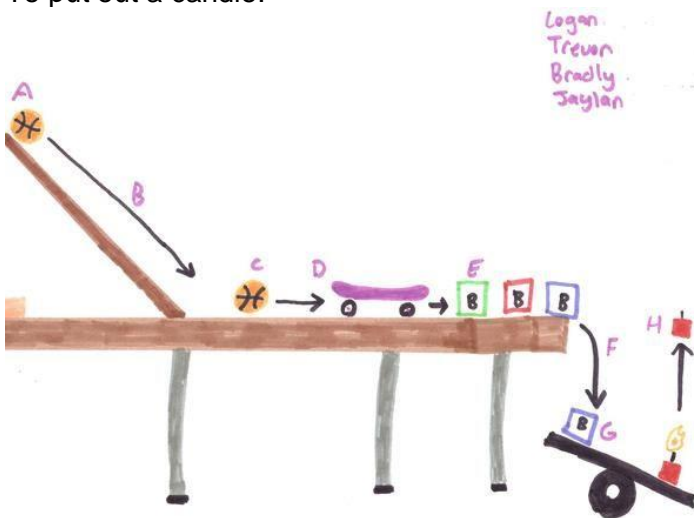
	<p>10-20 minutes</p>	<ul style="list-style-type: none"> ○ A machine is something that is designed to make our work easier. Give them examples: wheels, scissors, cars are all different types of machines ● Do machines move on their own? How does a bicycle move? <ul style="list-style-type: none"> ○ Let the learner reflect and answer ○ Explain that a bicycle works to move us from one point to another by applying force to the pedals <p>The learner will pick an item either from the house or his or her imagination, draw it, and write how it moves. If he or she cannot write yet, they can draw an arrow, zigzag line etc. to depict the motion of the item</p>
<p>2</p>	<p>5-10 minutes</p>	<p>Watch some videos of Rube Goldberg machines online to get the learner excited about building their own. If you do not have access to the internet, you can show them one of the images below:</p> <p>To secure coins:</p>  <p>Source:</p> <p>To put out a candle:</p>  <p>Source:</p>

	15 minutes	The learner will reflect on: <ul style="list-style-type: none"> • What is happening in this video/image? • Explain that a Rube Goldberg machine is a type of machine that is made to do something for us (such as pressing a button), and has many different parts connected to each other and move together to achieve the goal
	10 minutes	The learner will walk around the house collecting 5-10 items and place them on a table After the learner places all the items, ask him or her to write down in a notebook or piece of paper: <ul style="list-style-type: none"> • Name of item • How it works (if we need to push, pull, press etc.) <p>TIP: If the learner cannot write yet, you can either discuss with them and write the answer down, or write it in dotted lines and ask them to trace it</p>
3	2 minutes	Explain that today the learner will be creating their own Rube Goldberg machine at home! Tell him or her that a Rube Goldberg machine must meet the following criteria: <ul style="list-style-type: none"> • It should have many small parts arranged close to each other • It must do something at the end – like ring a bell, push a button etc.
	20-30 minutes	The learner will reflect on the type and purpose of the machine they want to make. They can watch more videos/images if needed to get some inspiration. Ask him or her to then draw the machine they want to build in their notebook or on a piece of paper using a pencil. examples: <ul style="list-style-type: none"> • a machine to put sugar in tea, made of a small ball, a few wooden popsicle sticks, a few sugar cubes and a cup with tea at the end • a machine to pop a balloon made of a small ball, toy car/Lego block/light stone with a pin attached, a wooden plank or popsicle sticks, and a balloon at the end
	10 minutes	Let the learner take the lead on designing the machine and allow them to test it without refining it Discussion: <ul style="list-style-type: none"> • What is the purpose of your machine? What is it making easier for you to do? • What items in our house do you think you can use to create your Rube Goldberg machine that you have drawn?
4	10-20 minutes	Time to test our design! Under your supervision, the learner will assemble all the items, allow her or him to set up and test a part of the machine, e.g. a toy car with a pin taped to the top sliding down a ramp made of popsicle sticks and popping a balloon. You can also create some items using paper or other adaptable material, if some items are unavailable

	10-20 minutes	After the setup is complete, ask them to get the machine going and observe what happens together Discussion: <ul style="list-style-type: none"> • What do you think worked? • What didn't work? • What can you change? (if it worked, ask them if they can expand the machine and add more parts and do something else)
	5-10 minutes	Give them feedback and ask them to refine their design and items list either to fix errors or expand the machine (by adding just one or two additional parts. Do not complicate the design). If the learner did not get it right this time, explain that designing a machine is a process and making mistakes is a part of it. Explain that this is the purpose of testing, so we can learn from our mistakes and make things work better.
5	10 minutes	The learner will refine the design of the machine based on yesterday's feedback by either expanding or refining it. They can draw the final design in color pens
	5-10 minutes	The learner will assemble all the items necessary and set up the modified machine for another testing round of the final design presented to the rest of the family!
	5 minutes	Start the machine!
	5 minutes	Discussion: <ul style="list-style-type: none"> • What do you think of your final design? • What do you think worked? • What didn't work? • What can you change?
Assessment Criteria:		Successful creation of a Rube Goldberg machine that consists of 3 or more simple and/or compound machines, and that solves some problem/serves some purpose.

Learning outcomes:	- Understanding of motion and force - Understanding of an example of a machine that uses force to work - Design and execution of a machine
Required previous learning:	Basic understanding of force and motion strand (G1 science)
Inspiration:	Simple and compound machines Engineering Kids Rube Goldberg Machine
Additional enrichment activities:	There is always room for extending the complexity of the final design by adding more items.

Ages 8 to 10 (Level 2)

Description:	Teach your learners the principles of engineering and the values of resilience, creativity, and attention to detail with this hands-on activity
Leading question:	How can we create a machine that helps us do something useful or fun in our house?
Age group:	8-10 years old
Subjects:	Science (physics, engineering)
Total time required:	~ 50-80 minutes per day – ~2.5-4 hours in total over 3 days
Self-guided / Supervised activity:	Supervised
Resources required:	Pencil, color pens, paper/notebook, household items to create the machine (ball, toy car, Lego blocks, tape, straws, cards, dominoes, strings, etc. - any items found at home)

Day	Time	Activity and Description
1	10-20 minutes	<p>Discussion:</p> <ul style="list-style-type: none"> • Do you know what a machine is? Why do we need machines? <ul style="list-style-type: none"> ○ Let the learner reflect and answer ○ Explain that a machine is something that is designed to make our work easier. Give them examples: there are simple machines like wheels, levers etc. and more complex ones called compound machines. Compound machines are made up of two or more simple machines • How do you think a machine, like a bicycle, for example, works? <ul style="list-style-type: none"> ○ Let the learner reflect and answer ○ Explain that a bicycle works to move us from one point to another by applying force to the pedals • How does a machine make our work easier? <ul style="list-style-type: none"> ○ Let the learner reflect and answer ○ Explain that machines work by increasing or changing the direction of force • Is everything a machine? Is a book a machine? Why or why not? <ul style="list-style-type: none"> ○ Explain that machines serve us by making it easier for us to do something. Not all objects are machines. E.g. books, clothes, boxes, cups are not machines. But scissors, wheels, knives etc. are machines
	5-10 minutes	<p>Watch some videos of Rube Goldberg machines online to get your learner excited about building their own. If you do not have access to the internet, you can show them one of the images included here</p> <p>To secure coins:</p>



To staple paper:

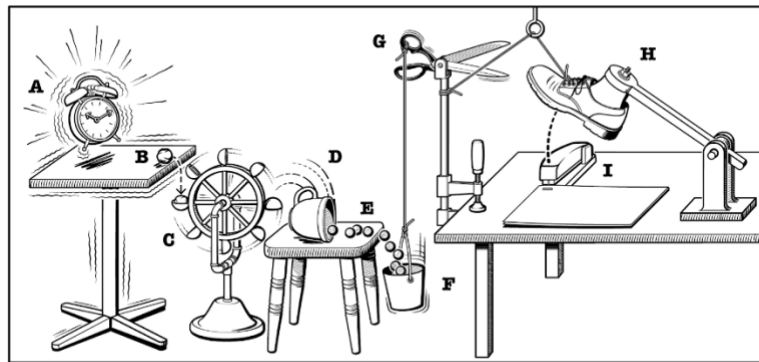

To spray a piece of cloth:



5
minutes

Discussion:

- Do you know what type of machine the Rube Goldberg one from the video you just watched/image you have just seen is
- Explain that a Rube Goldberg machine is a compound machine that is designed to “solve a problem” (such as pressing a button), and is composed of several simple and compound machines that are connected to each other such that exerting force on the first

	<p>15 minutes</p> <p>20-30 minutes</p>	<p>component to “start” the machine results in the exertion of force on the next component and so on until the last component is struck. You may provide this explanation after the next activity (discussion about machines)</p> <p>The learner will discover some machines at home! Tell them to spend some time walking around the house collecting 5-10 machines and to place them on a table</p> <p>After all the machines are placed on the table, ask him or her to write down in a notebook or piece of paper:</p> <ul style="list-style-type: none"> • Name of machine • Why they think this is a machine • What work does it make easier for us to do • How it works <p>If it is a simple or compound machine</p>
<p>2</p>	<p>2 minutes</p> <p>20-30 minutes</p> <p>(5-10 minutes)</p> <p>20 minutes</p>	<p>The learner will be creating their own Rube Goldberg machine at home! Tell him or her that a Rube Goldberg machine must meet the following criteria:</p> <ul style="list-style-type: none"> • It should be composed of many simple and compound machines • It must solve a problem at the end – like ring a bell, push a button etc. <p>The learner will reflect on the type and purpose of the machine they want to make and write this down in their notebook. They can watch more videos if needed to get some inspiration. The learner will then draw the machine they want to build in their notebook or on a piece of paper using a pencil. Examples:</p> <ul style="list-style-type: none"> • A machine to put sugar in tea, made of a small ball, a few wooden popsicle sticks, a few sugar cubes and a cup with tea at the end • A machine to pop a balloon made of a small ball, toy car/Lego block/light stone with a pin attached, a wooden plank or popsicle sticks, and a balloon at the end <p>Let the learner take the lead on designing the machine and allow them to test it without refining it</p> <p>Discussion (optional):</p> <ul style="list-style-type: none"> • What are the different types of machines we have seen in the videos/images? <ul style="list-style-type: none"> ○ You can provide hints by saying that there’s usually something that rolls, something that tilts, something that pulls/lifts etc. • What is the purpose of your machine? What is it making easier for you to do? What problem is it solving? • What items do you think you can use to create your Rube Goldberg machine you have drawn?

		<p>Using a similar list to the template below, the learner will gather all their toys or objects found in the house and write down what they think they can use in each category. Examples: balls, sticks, paper, ruler, bottles, bottle caps, cards, stones, candles, threads, pins, balloons etc. You can use any items you have at home or create ones out of paper or other easily adaptable material. The learner will then divide the items based on whether they roll, slide, pull etc.</p> <p>Template:</p> <p>Item Role Ruler To be the ramp/course for the ball to roll on Ball To slide down the ramp and knock off the cards Cards To be knocked off by a ball and fall on something else</p>
3-4	<p>10 minutes</p> <p>10-20 minutes</p> <p>10 minutes</p> <p>5 minutes</p> <p>5-10 minutes</p> <p>5 minutes</p> <p>10 minutes</p>	<p>Time to test the first design! The learner will assemble all the items and set up and test a part of the machine, e.g. a toy car with a pin taped to the top sliding down a ramp made of popsicles popping a balloon.</p> <p>Reminder: you can also create some items using paper or other material if some items are unavailable.</p> <p>After the setup is complete, the learner will get the machine going and observe what happens together</p> <p>Discussion:</p> <ul style="list-style-type: none"> • What do you think worked? • What didn't work? • What can you change? (if it worked, ask them if they can expand the machine and add more parts) <p>Give the learner feedback and ask them to refine their design and items list either to fix errors or expand the machine.</p> <p>If the learner did not get it right this time, explain that designing a machine is a process and making mistakes is a part of it. Explain that this is the purpose of testing, so we can learn from our mistakes and make things work better.</p> <p>The learner will refine the design of the machine based on the feedback by either expanding or refining it. They can draw the final design in color pens!</p> <p>The learner will set up and start the machine for another testing round of the final design</p> <p>Discussion:</p> <ul style="list-style-type: none"> • What do you think worked? • What didn't work? • What can you change?

	5 minutes	<p>The learner will make the necessary adjustments (if any) and set up the machine again to show their siblings/rest of the family! They will first explain the purpose of the machine, its different parts, and finally set it off!</p> <p>The learner will present the set up and start the machine again in front of the rest of the family!</p>
Assessment Criteria:		<ul style="list-style-type: none"> - Successful creation of a Rube Goldberg machine that consists of 5 or more simple and/or compound machines, and that solves some problem/serves some purpose. - Reiteration of design based on feedback - Presentation of final design

Learning outcomes:	<ul style="list-style-type: none"> - Understanding of simple and compound machines - Understanding of a Rube Goldberg machine - Design and execution of a machine
Required previous learning:	Basic understanding of force, motion, and energy strand (G3 science)
Inspiration:	Simple and compound machines Engineering Kids Rube Goldberg Machine
Additional enrichment activities:	<ul style="list-style-type: none"> - There is always room for extending the complexity of the final outcome by adding more items. - Older learners can also be asked to write a report documenting the process of creating the machine and detailing the types of component machines used, their operation mechanism etc.

Ages 11 to 14 (Level 3)

Description:	Teach your learners the principles of engineering and the values of resilience, creativity, and attention to detail with this hands-on activity
Leading question:	How can we create a machine that helps us do something useful or fun in our house?
Age group:	11-14 years old
Subjects:	Science (physics, engineering)
Total time required:	~ 50-80 minutes per day – ~3-5 hours in total over 4 days
Self-guided / Supervised activity:	Medium supervision
Resources required:	Pencil, color pens, paper/notebook, household items to create the machine (ball, toy car, Lego blocks, tape, straws, cards, dominoes, strings, etc. - any items found at home)

Day	Time	Activity and Description
1	10-20 minutes	<p>Discussion for revision of important concepts:</p> <ul style="list-style-type: none"> • What is a machine? What are the different types of machines? <ul style="list-style-type: none"> ○ Let the learner reflect and answer ○ A machine is something that is designed to make our work easier. Examples: there are simple machines and more complex ones called compound machines. ○ Simple machines: there are 6 types of simple machines: levers, pulleys, wheels and axles, screws, wedges, and inclined planes ○ Compound machines are made up of two or more simple machines • How do you think a machine, like a bicycle, for example, works? <ul style="list-style-type: none"> ○ Let the learner reflect and answer ○ Explain that a bicycle works to move us from one point to another by applying force to the pedals • What are Newton's three laws of motion? What state is a wheel that has not been turned in? what happens when we apply force? <ul style="list-style-type: none"> ○ Inertia, acceleration, action/reaction ○ An unturned wheel is in the state of inertia ○ If force is applied, the wheel's motion will be accelerated in a way that is proportional to the force applied. <p>Watch some videos of Rube Goldberg machines online to get your learner excited about building their own. If you do not have access to the internet, you can show them one of the images included here</p>
	5-10 minutes	

To secure coins:



To staple paper:

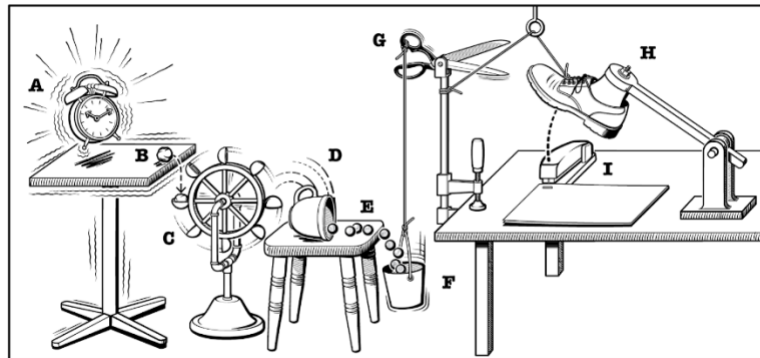

To spray a piece of cloth:



5 minutes

Discussion:

- What type of machine the Rube Goldberg one from the video you just watched/image you have just seen is? Simple or compound?
- A Rube Goldberg machine is a compound machine that is designed to “solve a problem” (such as pressing a button), and is

	15 minutes	composed of several simple and compound machines that are connected to each other such that exerting force on the first component to “start” the machine results in the exertion of force on the next component and so on until the last component is struck. You may provide this explanation after the next activity (discussion about machines)
	20-30 minutes	<p>The learner will discover some machines at home! Tell them to spend some time walking around the house collecting 5-10 machines and to place them on a table</p> <p>After all the machines are placed on the table, ask him or her to write down in a notebook or piece of paper:</p> <ul style="list-style-type: none"> • Name of machine • Why they think this is a machine • What work does it make easier for us to do? • How it works <p>If it is a simple or compound machine</p>
2	2 minutes	<p>The learner will be creating their own Rube Goldberg machine at home! The machine must meet the following criteria:</p> <ul style="list-style-type: none"> • It must include at least 3 types of simple machines: levers or pulleys, wheels, inclined planes • It must have at least 10 parts • It must solve a problem at the end – like ring a bell, push a button etc.
	20-30 minutes	<p>The learner will reflect on the type and purpose of the machine they want to make and write this down in their notebook. They can watch more videos if needed to get some inspiration. The learner will then draw the machine they want to build in their notebook or on a piece of paper using a pencil. Examples of basic designs to be expanded to 10 simple machines:</p> <ul style="list-style-type: none"> • A machine to put sugar in tea, made of a small ball, a few wooden popsicle sticks, a few sugar cubes and a cup with tea at the end • A machine to pop a balloon made of a small ball, toy car/Lego block/light stone with a pin attached, a wooden plank or popsicle sticks, and a balloon at the end
	(5-10 minutes)	<p>Let the learner take the lead on designing the machine and allow them to test it without refining it</p>
	20 minutes	<p>Discussion (optional):</p> <ul style="list-style-type: none"> • What is the purpose of your machine? What is it making easier for you to do? What problem is it solving? • What items do you think you can use to create your Rube Goldberg machine you have drawn?

		<p>Using a similar list to the template below, the learner will gather all their toys or objects found in the house and write down what they think they can use in each category. Examples: balls, sticks, paper, ruler, bottles, bottle caps, cards, stones, candles, threads, pins, balloons etc. You can use any items you have at home or create ones out of paper or other easily adaptable material. The learner will then divide the items based on whether they roll, slide, pull etc.</p> <p>Template:</p> <table border="1"> <thead> <tr> <th>Item</th> <th>Machine type</th> <th>Energy transfer</th> </tr> </thead> <tbody> <tr> <td>Ruler</td> <td>Inclined plane</td> <td></td> </tr> <tr> <td>Ball</td> <td>Wheel</td> <td>Cards</td> </tr> <tr> <td>Cards</td> <td></td> <td>Lever</td> </tr> </tbody> </table>	Item	Machine type	Energy transfer	Ruler	Inclined plane		Ball	Wheel	Cards	Cards		Lever
Item	Machine type	Energy transfer												
Ruler	Inclined plane													
Ball	Wheel	Cards												
Cards		Lever												
3	<p>10 minutes</p> <p>10-20 minutes</p> <p>10 minutes</p> <p>5 minutes</p> <p>10-20 minutes</p> <p>5 minutes</p> <p>10 minutes</p> <p>5 minutes</p>	<p>Time to test the first design! The learner will assemble all the items and set up and test the machine,</p> <p>Reminder: you can also create some items using paper or other material if some items are unavailable.</p> <p>After the setup is complete, the learner will get the machine going and observe what happens together</p> <p>Discussion:</p> <ul style="list-style-type: none"> • What do you think worked? • What didn't work? • What can you change? (if it worked, ask them if they can expand the machine and add more parts) <p>Give the learner feedback and ask them to refine their design and items list either to fix errors or expand the machine.</p> <p>If the learner did not get it right this time, explain that designing a machine is a process and making mistakes is a part of it. Explain that this is the purpose of testing, so we can learn from our mistakes and make things work better.</p> <p>The learner will record his or her observations from the first trial and refine the design of the machine based on the feedback by either expanding or refining it. They can draw the final design in color pens!</p> <p>The learner will set up and start the machine for another testing round of the final design</p> <p>Discussion:</p> <ul style="list-style-type: none"> • What do you think worked? • What didn't work? • What can you change? 												

		<p>The learner will make the necessary adjustments (if any) and set up the machine again to show their siblings/rest of the family! They will first explain the purpose of the machine, its different parts, and finally set it off!</p> <ul style="list-style-type: none"> The learner will present the set up and start the machine again in front of the rest of the family!
5	30-60 minutes	<p>The learner will use the documentation of the process of creating the machine to produce a final report with the following sections:</p> <ul style="list-style-type: none"> Purpose of machine Simple machines used: <ul style="list-style-type: none"> Type of simple machine: e.g.: a wooden stick was used as an inclined plane Newton's three laws of motion and where they were observed: list the laws and describe where in the process you observed them. E.g.: before I started the machine, the first object was in a state of inertia (first law) Observations of kinetic energy transfer: e.g.: when I started the machine by releasing a thread and paper cup pulley attached to a stone, the energy from the falling stone was transferred onto a wooden stick lever, causing the load on the other end of the lever to fly upwards First design description: setup and result Second or final design: modifications to first design, set up and result Conclusion: do you think the way you engineered the machine was successful? What would you change, if anything? <p>The learner can refer to his or her science textbook or perform a quick desktop search of the laws of motion or other information needed to complete the report.</p>
Assessment Criteria:		<ul style="list-style-type: none"> - Successful creation of a Rube Goldberg machine that consists of 10 or more simple and/or compound machines, and that solves some problem/serves some purpose. - Reiteration of design based on feedback - Presentation of final design - Reporting on experience
Learning outcomes:		<ul style="list-style-type: none"> - Understanding of simple and compound machines - Understanding of a Rube Goldberg machine - Design and execution of a machine
Required previous learning:		Basic understanding of force, motion, and energy strand (G7 science)
Inspiration:		Simple and compound machines Engineering Kids Rube Goldberg Machine

<p>Additional enrichment activities:</p>	<ul style="list-style-type: none"> • There is always room for extending the complexity of the final outcome by adding more items and simple machines to the design • Additional topics that can be covered in discussion and final report: <ul style="list-style-type: none"> ○ Potential energy ○ Kinetic energy ○ Speed ○ Velocity • Example of questions that can be asked: if you have a scale, timer/stopwatch and ruler, ask the learner to calculate the kinetic energy of the ball by using $KE = \frac{1}{2} (mv^2)$, where KE = kinetic energy m =mass in kg v = velocity in meters per second
--	--